

# HD74LS92 • Divide-by-Twelve Counters

The HD74LS92 contains four master-slave flip-flops and additional gating to provide a divide-by-two counter and three-stage binary counter for divide-by-six. To use this maximum count length of this counter, the B input is connected to the  $Q_A$  output. The input count pulses are applied to input A and the outputs are described in the appropriate function table.

## ■ BLOCK DIAGRAM

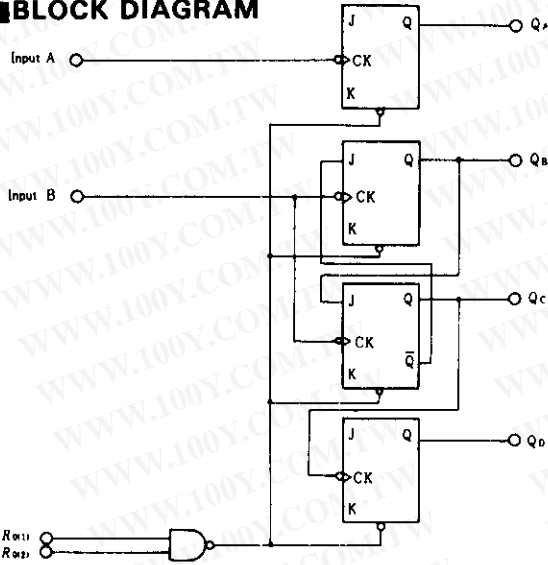

## ■ FUNCTION TABLE

Reset/Count Function Table

Reset Inputs		Outputs			
$R_{0(1)}$	$R_{0(2)}$	$Q_D$	$Q_C$	$Q_B$	$Q_A$
H	H	L	L	L	L
L	X	Count			
X	L	Count			

BCD Count Sequence (Notes 1)

Count	Output			
	$Q_D$	$Q_C$	$Q_B$	$Q_A$
0	L	L	L	L
1	L	L	L	H
2	L	L	H	L
3	L	L	H	H
4	L	H	L	L
5	L	H	L	H
6	H	L	L	L
7	H	L	L	H
8	H	L	H	L
9	H	L	H	H
10	H	H	L	L
11	H	H	L	H

Notes) 1. Output  $Q_A$  is connected to input B for BCD count.  
3. H; high level, L; low level, X; irrelevant

## ■ PIN ARRANGEMENT

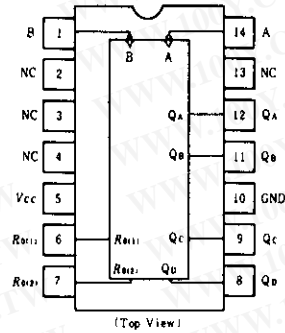

## ■ ABSOLUTE MAXIMUM RATINGS

Item	Symbol	Ratings	Unit
Supply voltage	$V_{CC}$	7.0	V
Input voltage	R Input	7.0	V
	A, B Input	5.5	V
Operating temperature range	$T_{opr}$	-20 ~ +75	°C
Storage temperature range	$T_{stg}$	-65 ~ +150	°C

## ■ RECOMMENDED OPERATING CONDITIONS

Item	Symbol	min	typ	max	Unit
Count frequency	A input	0	-	32	MHz
	B input	0	-	16	
Pulse width	A input	15	-	-	ns
	B input	30	-	-	
	Reset inputs	15	-	-	
Setup time	$t_{su}$	25	-	-	ns

## ■ TIMING DEFINITION

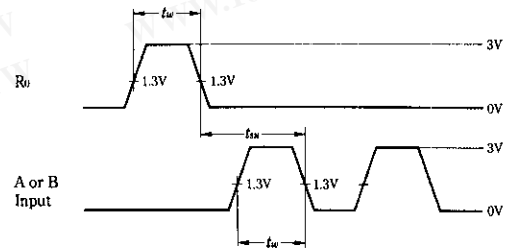

勝特力材料 886-3-5753170  
 勝特力电子(上海) 86-21-54151736  
 勝特力电子(深圳) 86-755-83298787  
[Http://www.100y.com.tw](http://www.100y.com.tw)

## ■ ELECTRICAL CHARACTERISTICS ( $T_a = -20 \sim +75^\circ\text{C}$ )

Item	Symbol	Test Conditions		min	typ*	max	Unit
Input voltage	$V_{IH}$			2.0	-		V
	$V_{IL}$			-	-	0.8	V
Output voltage	$V_{OH}$	$V_{CC} = 4.75\text{V}$ , $V_{IH} = 2\text{V}$ , $V_{IL} = 0.8\text{V}$ , $I_{OH} = -400\mu\text{A}$		2.7	-		V
	$V_{OL}$	$V_{CC} = 4.75\text{V}$ , $V_{IH} = 2\text{V}$ , $I_{OL} = 4\text{mA}^{**}$		-	-	0.4	V
	$V_{OL}$	$V_{IL} = 0.8\text{V}$ , $I_{OL} = 8\text{mA}^{**}$		-	-	0.5	V
Input current	Any Reset			-	-	0.4	mA
	A input	$I_{IL}$	$V_{CC} = 5.25\text{V}$ , $V_I = 0.4\text{V}$	-	-	2.4	
	B input			-	-	3.2	
	Any Reset	$I_{IH}$	$V_{CC} = 5.25\text{V}$ , $V_I = 2.7\text{V}$	-	-	20	$\mu\text{A}$
	A input			-	-	40	
	B input			-	-	80	
Any Reset	$I_I$	$V_{CC} = 5.25\text{V}$	$V_I = 7\text{V}$	-	-	0.1	mA
A input			$V_I = 5.5\text{V}$	-	-	0.2	
B input				-	-	0.4	
Short circuit output current	$I_{OS}$	$V_{CC} = 5.25\text{V}$		-20	-	100	mA
Supply current ***	$I_{CC}$	$V_{CC} = 5.25\text{V}$		-	9	15	mA
Input clamp voltage	$V_{IK}$	$V_{CC} = 4.75\text{V}$ , $I_{IK} = -18\text{mA}$		-	-	1.5	V

\*  $V_{CC} = 5\text{V}$ ,  $T_a = 25^\circ\text{C}$   
 \*\*  $Q_A$  output is tested at specified  $I_{OL}$  plus the limit value of  $I_{IL}$  for the B input. This permits driving the B input while maintaining full fan-out capability.

\*\*\*  $I_{CC}$  is measured with all outputs open both  $R_o$  inputs grounded following momentary connection to 4.5V, and all other inputs grounded.

## ■ SWITCHING CHARACTERISTICS ( $V_{CC} = 5\text{V}$ , $T_a = 25^\circ\text{C}$ )

Item	Symbol	Input	Outputs	Test Conditions	min	typ	max	Unit
Maximum count frequency	$f_{max}$	A	$Q_A$	$C_L = 15\text{pF}$ , $R_L = 2\text{k}\Omega$	32	42	-	MHz
		B	$Q_B$		16	-	-	MHz
Propagation delay time	$t_{PLH}$	A	$Q_A$		-	10	16	ns
					$t_{PHL}$	$Q_A$	-	12
	$t_{PLH}$	A	$Q_D$				-	32
					$t_{PHL}$	$Q_D$	-	34
	$t_{PLH}$	B	$Q_B$				-	10
					$t_{PHL}$	$Q_B$	-	14
	$t_{PLH}$	B	$Q_C$				-	10
					$t_{PHL}$	$Q_C$	-	14
	$t_{PLH}$	B	$Q_D$	-			21	32
				$t_{PHL}$	$Q_D$	-	23	35
$t_{PHL}$	Set to 0	$Q_A - Q_D$	-			26	40	ns

## TESTING METHOD

### 1) Test Circuit

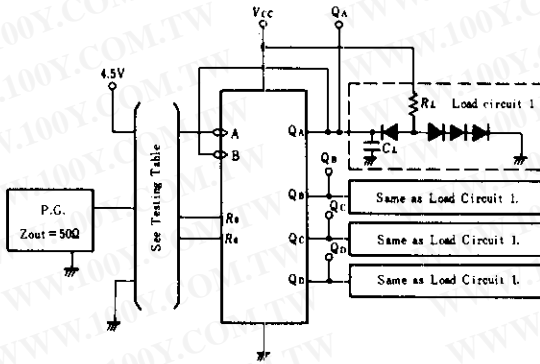

- Notes) 1. Input pulse;  $t_{TLH} \leq 15ns$ ,  $t_{THL} \leq 6ns$ ,  $PRR = 1MHz$ , duty cycle=50%  
 2.  $C_L$  includes probe and jig capacitance.  
 3. All diodes are 1S2074  $\oplus$ .

### 2) Testing Table

Item	From input to output	Inputs			Outputs			
		A	B	$R_0$	$Q_A$	$Q_B$	$Q_C$	$Q_D$
$f_{max}$	A $\rightarrow$ Q	IN	to $Q_A$	GND	Out	Out	Out	Out
	B $\rightarrow$ Q	4.5V	IN	GND	-	Out	Out	Out
$t_{PLH}$	A $\rightarrow$ $Q_A$	IN	to $Q_A$	GND	Out	-	-	-
	A $\rightarrow$ $Q_D$	IN	to $Q_A$	GND	-	-	-	Out
$t_{PHL}$	B $\rightarrow$ $Q_B$	4.5V	IN	GND	-	Out	-	-
	B $\rightarrow$ $Q_D$	4.5V	IN	GND	-	-	Out	-
	B $\rightarrow$ $Q_D$	4.5V	IN	GND	-	-	-	Out
	$R_0 \rightarrow$ Q	IN*	to $Q_A$	IN	Out	Out	Out	Out

\*; For initialized.

\*\*; Measured with each input and unused inputs at 4.5V.

勝特力材料 886-3-5753170  
 勝特力电子(上海) 86-21-54151736  
 勝特力电子(深圳) 86-755-83298787  
[Http://www.100y.com.tw](http://www.100y.com.tw)

Waveform-1  $f_{max}$ ,  $t_{PLH}$ ,  $t_{PHL}$ (Clock  $\rightarrow$  Q)

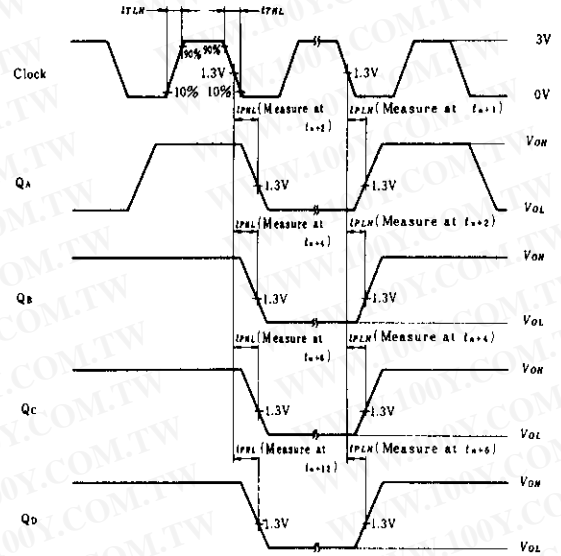

- Notes) 1. Input pulse;  $t_{TLH} \leq 15ns$ ,  $t_{THL} \leq 6ns$ ,  $PRR = 1MHz$ , duty cycle=50% and: for  $f_{max}$ ,  $t_{PLH} = t_{THL} \leq 2.5ns$ .  
 2.  $t_n$  is reference bit time when all outputs are low.

Waveform-2  $t_{PHL}$ ( $R_0 \rightarrow$  Q)

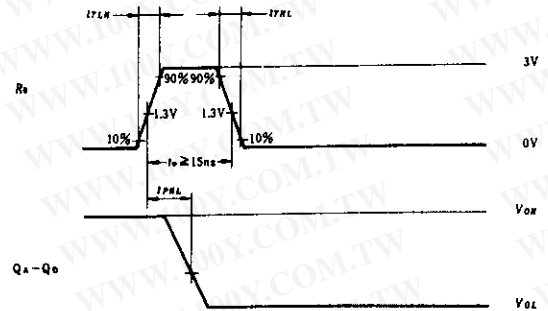

- Notes) 1.  $t_{TLH} \leq 15ns$ ,  $t_{THL} \leq 6ns$ .

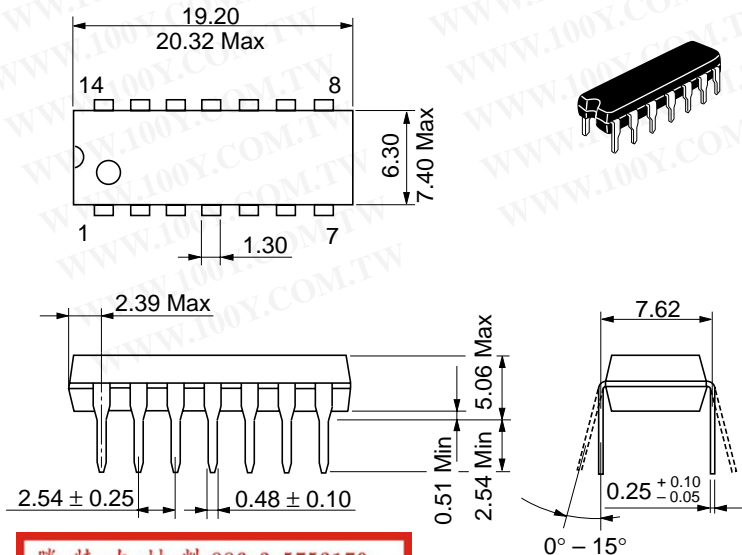

勝特力材料 886-3-5753170  
 勝特力电子(上海) 86-21-54151736  
 勝特力电子(深圳) 86-755-83298787  
[Http://www.100y.com.tw](http://www.100y.com.tw)

Hitachi Code	DP-14
JEDEC	Conforms
EIAJ	Conforms
Weight (reference value)	0.97 g

Unit: mm

勝特力材料 886-3-5753170  
 勝特力电子(上海) 86-21-54151736  
 勝特力电子(深圳) 86-755-83298787  
[Http://www.100y.com.tw](http://www.100y.com.tw)

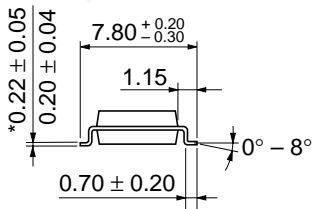
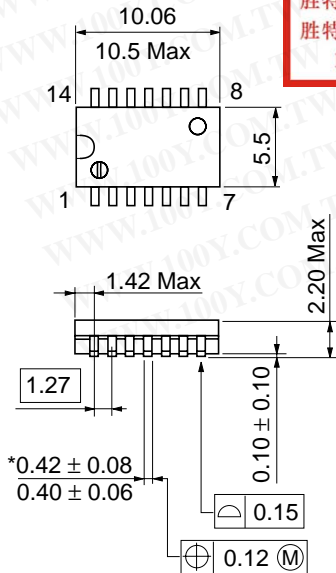
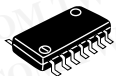

\*Dimension including the plating thickness  
 Base material dimension

Hitachi Code	FP-14DA
JEDEC	—
EIAJ	Conforms
Weight (reference value)	0.23 g

勝特力材料 886-3-5753170  
 勝特力电子(上海) 86-21-54151736  
 勝特力电子(深圳) 86-755-83298787  
[Http://www.100y.com.tw](http://www.100y.com.tw)

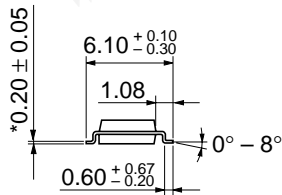
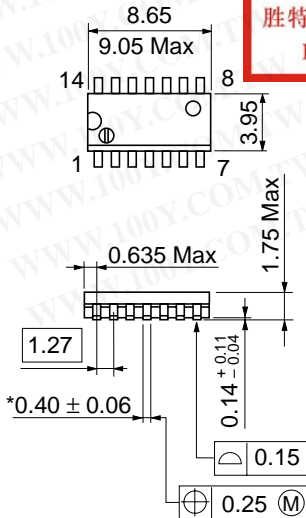

Hitachi Code	FP-14DN
JEDEC	Conforms
EIAJ	Conforms
Weight (reference value)	0.13 g

勝特力材料 886-3-5753170

勝特力电子(上海) 86-21-54151736

勝特力电子(深圳) 86-755-83298787

[Http://www.100y.com.tw](http://www.100y.com.tw)

## Cautions

1. Hitachi neither warrants nor grants licenses of any rights of Hitachi's or any third party's patent, copyright, trademark, or other intellectual property rights for information contained in this document. Hitachi bears no responsibility for problems that may arise with third party's rights, including intellectual property rights, in connection with use of the information contained in this document.
2. Products and product specifications may be subject to change without notice. Confirm that you have received the latest product standards or specifications before final design, purchase or use.
3. Hitachi makes every attempt to ensure that its products are of high quality and reliability. However, contact Hitachi's sales office before using the product in an application that demands especially high quality and reliability or where its failure or malfunction may directly threaten human life or cause risk of bodily injury, such as aerospace, aeronautics, nuclear power, combustion control, transportation, traffic, safety equipment or medical equipment for life support.
4. Design your application so that the product is used within the ranges guaranteed by Hitachi particularly for maximum rating, operating supply voltage range, heat radiation characteristics, installation conditions and other characteristics. Hitachi bears no responsibility for failure or damage when used beyond the guaranteed ranges. Even within the guaranteed ranges, consider normally foreseeable failure rates or failure modes in semiconductor devices and employ systemic measures such as fail-safes, so that the equipment incorporating Hitachi product does not cause bodily injury, fire or other consequential damage due to operation of the Hitachi product.
5. This product is not designed to be radiation resistant.
6. No one is permitted to reproduce or duplicate, in any form, the whole or part of this document without written approval from Hitachi.
7. Contact Hitachi's sales office for any questions regarding this document or Hitachi semiconductor products.

---

---

# HITACHI

HITACHI