



勝特力材料 886-3-5753170
 勝特力电子(上海) 86-21-54151736
 勝特力电子(深圳) 86-755-83298787
 Http://www.100y.com.tw

BYV32, BYVF32 & BYVB32 Series

Vishay Semiconductors
 formerly General Semiconductor

Dual Ultrafast Rectifiers

Reverse Voltage 50 to 200V
 Forward Current 18A
 Reverse Recovery Time 25ns

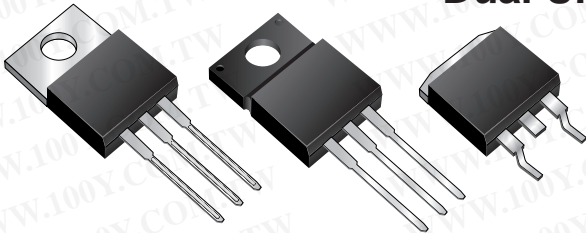

TO-220AB (BYV32 Series)

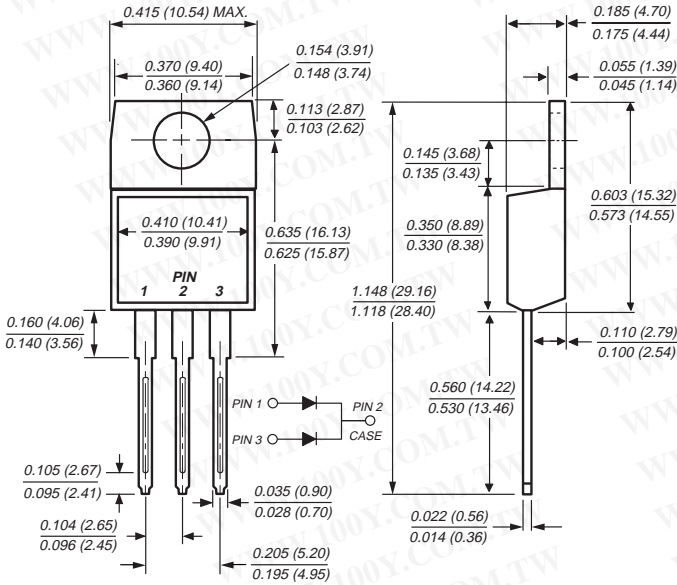

ITO-220AB (BYVF32 Series)

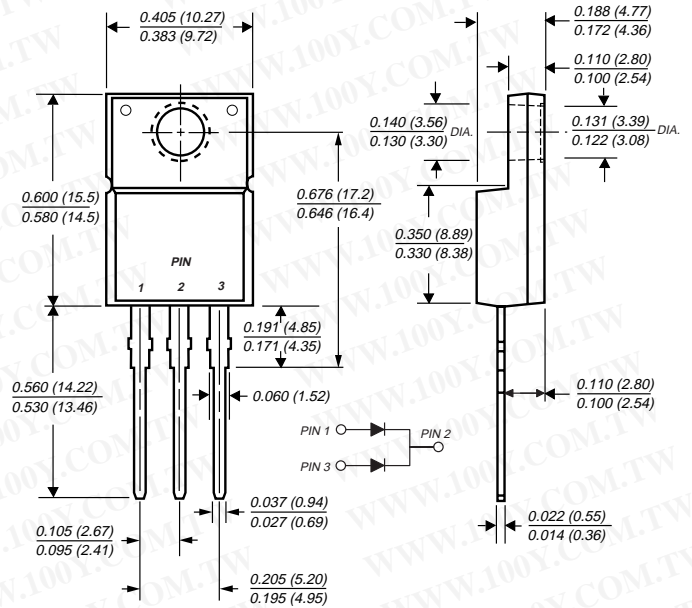

Mounting Pad Layout TO-263AB

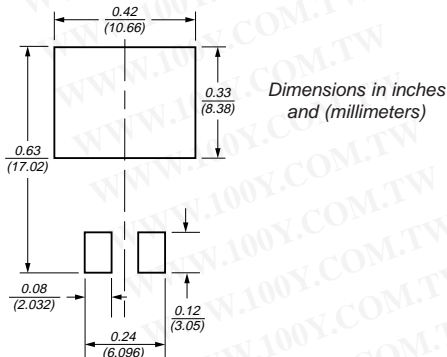

TO-263AB (BYVB32 Series)

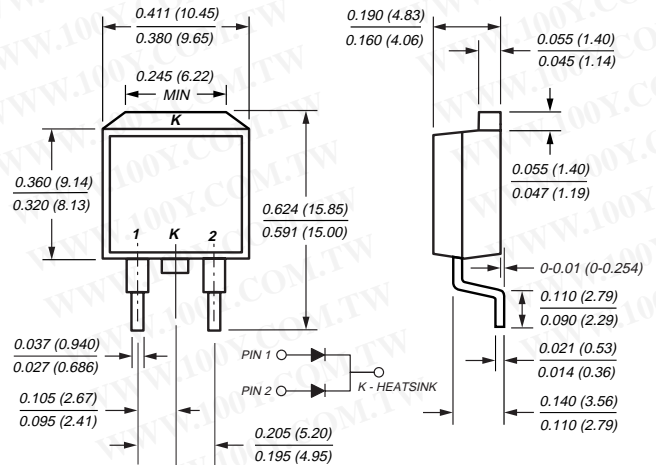

Features

- Plastic package has Underwriters Laboratory Flammability Classification 94V-0
- Dual rectifier construction, positive centertap
- Glass passivated chip junctions
- Low power loss
- Low forward voltage, high current capability
- High surge current capability
- Superfast recovery times for high efficiency

Mechanical Data

Case: JEDEC TO-220AB, ITO-220AB & TO-263AB molded plastic body

Terminals: Plated leads, solderable per MIL-STD-750, Method 2026

High temperature soldering guaranteed: 250°C, 0.16" (4.06mm) from case for 10 seconds

Polarity: As marked **Mounting Position:** Any

Mounting Torque: 10 in-lbs maximum

Weight: 0.08 oz., 2.24 g

BYV32, BYVF32 & BYVB32 Series

Vishay Semiconductors
formerly General Semiconductor



勝特力材料 886-3-5753170
勝特力电子(上海) 86-21-54151736
勝特力电子(深圳) 86-755-83298787
[Http://www.100y.com.tw](http://www.100y.com.tw)

Maximum Ratings (T_C = 25°C unless otherwise noted)

Parameter	Symbol	BYV32-50	BYV32-100	BYV32-150	BYV32-200	Unit
Maximum repetitive peak reverse voltage	V _{RRM}	50	100	150	200	V
Maximum RMS voltage	V _{RMS}	35	70	105	140	V
Maximum DC blocking voltage	V _{DC}	50	100	150	200	V
Maximum average forward rectified current at T _C = 125°C	I _{F(AV)}	18				A
Peak forward surge current 8.3ms single half sine-wave superimposed on rated load (JEDEC Method) per leg	I _{FSM}	150				A
Operating junction and storage temperature range	T _J , T _{STG}	-65 to +150				°C
RMS Isolation voltage (BYVF type only) from terminals to heatsink with t = 1.0 second, RH ≤ 30%	V _{ISOL}	4500 ⁽¹⁾ 3500 ⁽²⁾ 1500 ⁽³⁾				V

Electrical Characteristics (T_C = 25°C unless otherwise noted)

Parameter	Symbol	BYV32-50	BYV32-100	BYV32-150	BYV32-200	Unit
Maximum instantaneous forward voltage per leg at: ⁽⁴⁾ at I _F = 20A at I _F = 5.0A, T _J = 100°C	V _F		1.15 0.85			V
Maximum DC reverse current per leg at rated DC blocking voltage T _J = 25°C T _J = 100°C	I _R		10 600			μA
Maximum reverse recovery time per leg at I _F = 1A, V _R = 30V, di/dt = 100A/μs, I _{rr} = 10% I _{RM}	t _{rr}		25			ns
Typical junction capacitance per leg at 4V, 1MHz	C _J		45			pF

Thermal Characteristics (T_C = 25°C unless otherwise noted)

Parameter	Symbol	BYV	BYVF	BYVB	Unit
Thermal resistance from junction to case per leg	R _{θJC}	1.6	5.0	1.6	°C/W

Notes:

- (1) Clip mounting (on case), where lead does not overlap heatsink with 0.110" offset
- (2) Clip mounting (on case), where leads do overlap heatsink
- (3) Screw mounting with 4-40 screw, where washer diameter is ≤ 4.9mm (0.19")
- (4) Pulse test: 300μs pulse width, 1% duty cycle



勝特力材料 886-3-5753170
 勝特力电子(上海) 86-21-54151736
 勝特力电子(深圳) 86-755-83298787
[Http://www.100y.com.tw](http://www.100y.com.tw)

BYV32, BYVF32 & BYVB32 Series

Vishay Semiconductors
formerly General Semiconductor

Ratings and Characteristic Curves (T_A = 25°C unless otherwise noted)

Forward Current Derating Curve

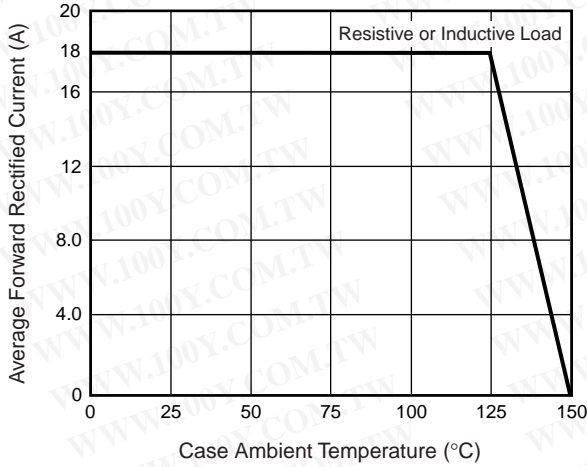

Maximum Non-Repetitive Peak Forward Surge Current Per Leg

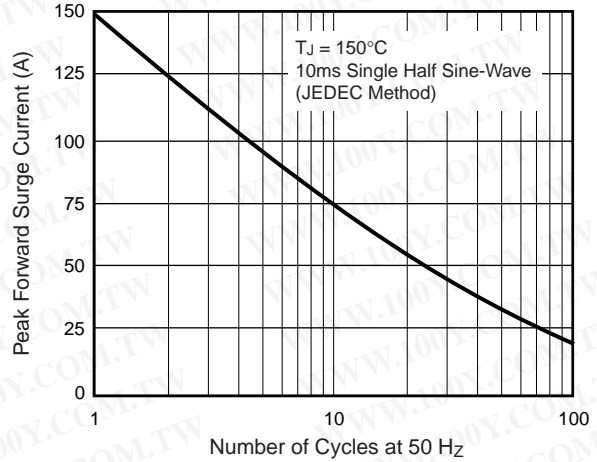

Typical Instantaneous Forward Characteristics Per Leg

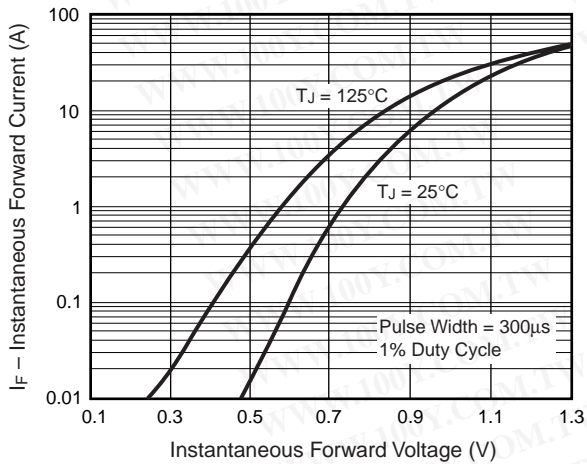

Typical Reverse Leakage Characteristics Per Leg

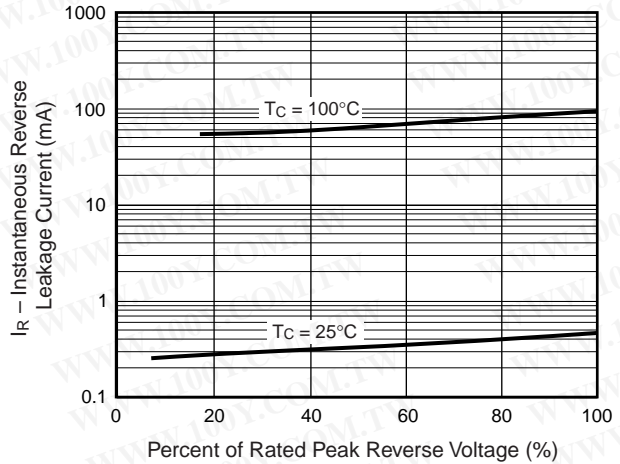

Typical Junction Capacitance Per Leg

